

Lubricate all seals with clean hydraulic fluid prior to assembly.  
Do not use silicone based lubricants.

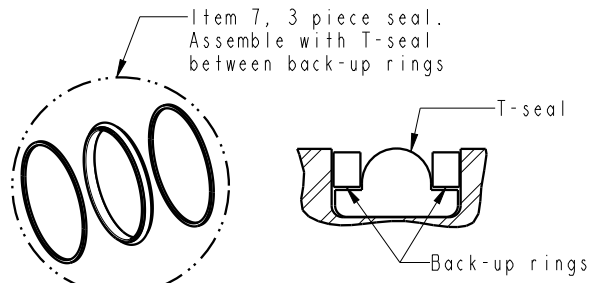
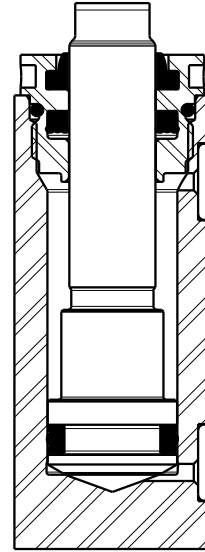
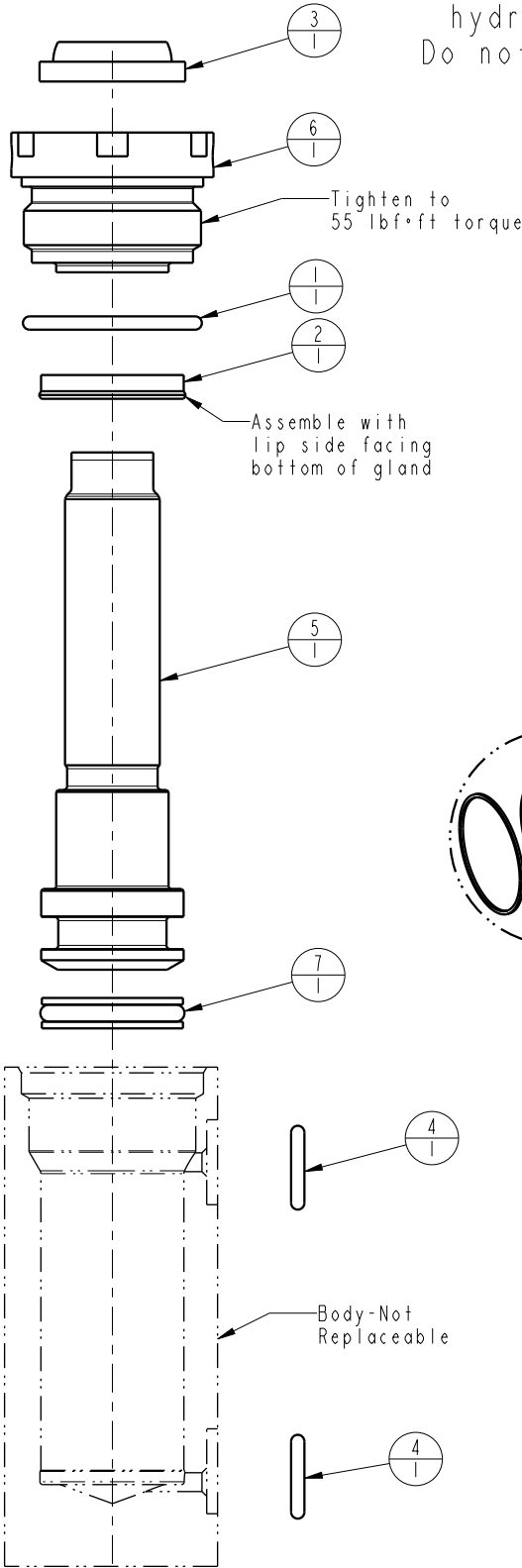

Standard Seal Kit	Fluorocarbon Seal Kit
60-2102-02	6V-2102-02
39-H100-16	39-V100-16
39-0500-42(2 ea)	39-0510-25(2 ea)
39-0000-13	39-0120-12
39-0100-19	39-0120-04
39-0120-11	39-0120-11

No.	QTY	PART No.	DESCRIPTION
7	1	39H10016	SEAL,T, (9/16 X 5/32 X 3/4)
6	1	82030802	GLAND, CYL, BB, DA, 2200
5	1	82010804	PISTON,CYL,BB ,2200, .75 STRK
4	2	39050042	O-RING, (-011)
3	1	39012011	WIPER,SNAP-IN, (1/2)
2	1	39010019	SEAL, LL, (1/2 X 1/8 X 1/8 X 3/4)
1	1	39000013	O-RING, (-019)

### PARTS LIST



VEKTEK, INC.  
1334 E. SIXTH AVE. P.O. BOX 625  
EMPORIA, KS. 66801 U.S.A.

Model Number  
21-1208-01  
21-1208-01F  
S64087-01

ASSY, CYL, BB, MM, 2200, .75 STRK, DA

SIZE  
A

PL2172

REV  
F

FORM FEG035\_PL\_ASIZE, REV. B

F	5499	RELEASE	NPETERS	9/23/24
REV	IN ACCORDANCE WITH ECN	EFFECTIVE DATE	REVISED BY	DATE
DRW BY:	JACOB	DRAWING STATUS: Released		
DATE:	3-13-00	PRODUCTION APPROVED FOR RELEASED STATUS ONLY		

SHEET 1 OF 1